



NEA

NEA

**Tecnologia e modularità
per immaginare qualsiasi tipologia di locale.**

Technology and modularity to imagine
any bar typology.

index

- pag. 04 pasticceria_caffetteria
NEA lineare
- pag. 20 food_panetteria
NEA angolo
- pag. 28 pasticceria_gelateria
NEA con pozzetto
- pag. 30 tecniche
NEA sezioni





NEA

PASTICCERIA _ CAFFETTERIA

Nea è una soluzione modulare. Nea è un progetto dinamico. Un'unità base che fornisce la perfetta integrazione di molteplici elementi, dalla vasca canalizzata multifunzionale, ai basamenti neutri o refrigerati.

Nea is a modular system. Nea is a dynamic project. It's a basic unit that provides the perfect integration of many elements, from multifunctional canalized tank to neutral or refrigerated base.



**Tecnologia che si combina
e dà vita al racconto di un luogo**
Technology combining to create the story of a place





PASTICCERIA_CAFFETTERIA

Nea è un banco espositivo che garantisce un'impeccabile visione degli alimenti, in linea con le attuali tendenze del mercato. Vasca e teca sono disponibili con vetri bassi, con vetri alti e mensola intermedia, con dettagli ricercati come la saldatura dei vetri a 45°.

Nea display counter ensures impeccable food view, in line with current market trends. Tanks and showcases are available with low glass, high glass and middle shelf, and also with sophisticated details such as 45° glass welding.





COFFEE MENU

- Cappuccino P 1.20
- Mocha P 1.20
- Espresso P 0.80
- Macchiato P 1.10
- Latte P 1.20
- Starkaffee P 0.80

SOUP OF THE DAY

2.00

BREAKFAST ITEMS

- Pull breakfast 4.00
- Breakfast roll 2.50
- Omelette 3.00
- Waffle 2.50
- Donut 1.50
- Yogurt 2.00

ANHEUSER-BUSCH
PROPERTY



PASTICCERIA_CAFFETTERIA

Con Nea ogni prodotto è collocato all'altezza più corretta. Cibi dolci e salati possono così beneficiare di una visibilità ottimale. Sulla vasca, l'apertura con pistoni a gas permette di sollevare il piano espositivo e l'evaporatore con un semplice gesto. L'assenza di particolari strutturali sul fondo consente una pulizia accurata e favorisce il mantenimento dell'igiene.

In Nea all products are placed at the most correct height. Sweet and savoury food can thus take advantage of the best visibility. In the tank, the gas piston opening system lets the display surface and the evaporator be lifted with a simple touch. The lack of structural details in the bottom area allows thorough cleaning and helps maintain hygiene.







Raffinatezza tecnica al servizio di architetti e arredatori
Technical refinement serving architects and interior designers





PASTICCERIA_CAFFETTERIA

La linearità dell'acciaio e del vetro può essere completata con qualunque stile d'arredamento. Ogni scelta di design può fare affidamento su prestazioni di elevato livello.

Il sistema di refrigerazione, ad esempio, assicura il massimo rendimento grazie alle modalità ventilata, refrigerata per pralineria, caldo secco e doppia funzione caldo-freddo.

Nea è disponibile anche nella fornitura esclusiva dell'elemento vasca, sia singola sia con vasche canalizzate.

Steel and glass linearity can be completed with any furniture style. Each design choice can rely on high-level performances. The refrigeration system, for instance, provides maximum efficiency thanks to its ventilated, for-pralines refrigerated, dry hot and double function hot-cold modes.

Nea also gives the option to order only the tank unit, both with single tank and canalized tanks.





L'eleganza e la funzionalità dei moduli canalizzabili
The elegance and functionality of the canalized modules





NEA

FOOD_PANETTERIA

La perfetta canalizzazione tra più moduli crea un'unica superficie espositiva, senza interruzioni, e genera capienza e praticità. Il raccordo ad angolo retto è un'ulteriore opzione studiata per adattarsi alle esigenze del locale e migliorarne l'efficienza.

Perfectly canalized modules create a single continuous display surface, bringing capacity and convenience. The right-angled joint is another option designed to suit the needs of the bar and to improve its efficiency.

Reinterpretare gli spazi con libertà e personalità

Reinterpreting spaces with freedom and personality





FOOD_PANETTERIA

Il modulo Nea è proposto nelle versioni da 850, 1250, 1650 e 2050 mm. Tra le opzioni di personalizzazione non mancano le celle di riserva, inseribili nei moduli refrigerati e neutri.

Nea modules are available in the 850, 1250, 1650 e 2050 mm versions. Among the customization options there are the spare cabinets, which can integrate in the refrigerated modules and in the counters.







Con l'impostazione modulare, la creazione di un locale diventa un processo aperto e dinamico. Ogni singolo modulo può espandersi secondo lo schema che si desidera, integrando le funzioni, gli strumenti o le tipologie di vetrina di cui il locale ha realmente bisogno.

With the modular approach, designing a bar becomes an open and dynamic process. Each module can expand according to a desired layout, adding functions, tools or the showcase types whom the bar really needs.







PASTICCERIA_GELATERIA

Nea è soprattutto una soluzione eclettica e versatile. Rappresenta il supporto ideale per una grande varietà di prodotti alimentari: pasticceria, pralineria, ma anche pane, pizza, fino ad arrivare al gelato. L'integrazione con i sistemi per la gelateria BRX è totale. Così, il locale diversifica la propria offerta e acquisisce nuove opportunità di business.

Above all, Nea is an eclectic and versatile structure. It's an ideal support for a great variety of foods: pastry, pralines, bread, pizza, and ice cream too. It provides a full integration with BRX ice cream systems, so that a bar is able to diversify its products and gain new business opportunities.

MODULO CON VASCA E TECA VETRI ALTI
MODULE WITH TUB AND HIGH GLASS STRUCTURE

MODULO CON VASCA E TECA VETRI BASSI
MODULE WITH TUB AND LOW GLASS STRUCTURE

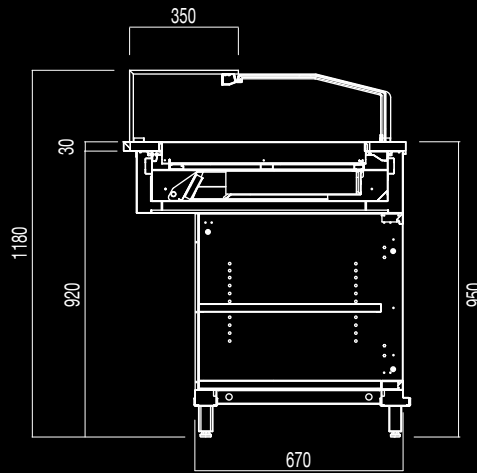
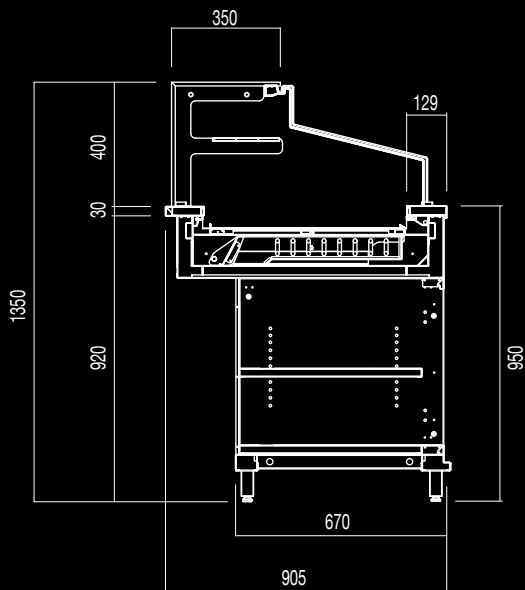

MODULI NEA: 850 / 1250 / 1650 / 2050
NEA DISPLAY CASE MODULES: 850 / 1250 / 1650 / 2050

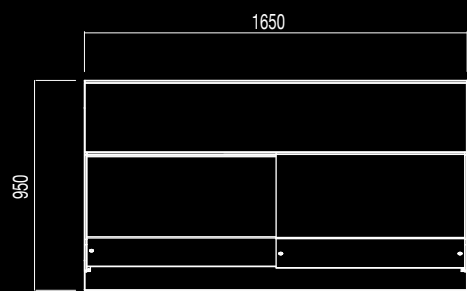
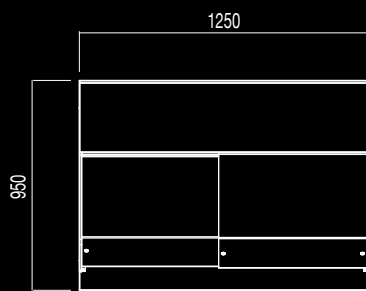
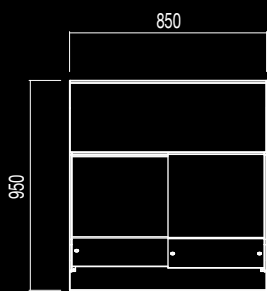

REFRIGERATO VENTILATO
REFRIGERATED VENTILATED

REFRIGERATO VENTILATO
REFRIGERATED VENTILATED

REFRIGERATO VENTILATO
REFRIGERATED VENTILATED

REFRIGERATO PER PRALINERIA
REFRIGERATED FOR PRALINE DISPLAY CASE

REFRIGERATO PER PRALINERIA
REFRIGERATED FOR PRALINE DISPLAY CASE

REFRIGERATO PER PRALINERIA
REFRIGERATED FOR PRALINE DISPLAY CASE

**REFRIGERATO DOPPIA
 FUNZIONE CALDO FREDDO**
*REFRIGERATED WITH DOUBLE
 SYSTEM HOT/COLD*

**REFRIGERATO DOPPIA
 FUNZIONE CALDO FREDDO**
*REFRIGERATED WITH DOUBLE
 SYSTEM HOT/COLD*

**REFRIGERATO DOPPIA
 FUNZIONE CALDO FREDDO**
*REFRIGERATED WITH DOUBLE
 SYSTEM HOT/COLD*

MODULO CON VASCA
MODULE WITH TUB

MODULO CON CELLA REFRIGERATA E VASCA
MODULE WITH REFRIGERATED CABINET AND TUB

VASCA
TUB

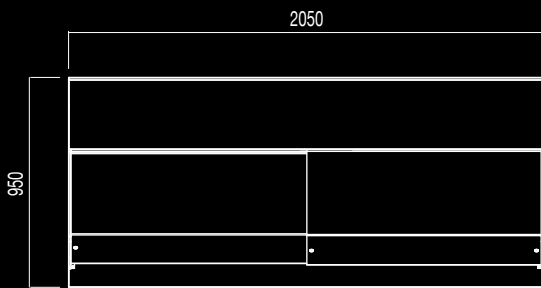
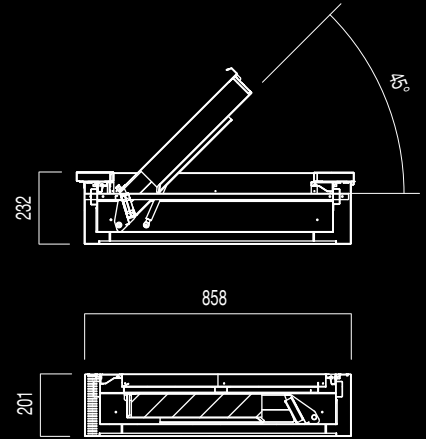
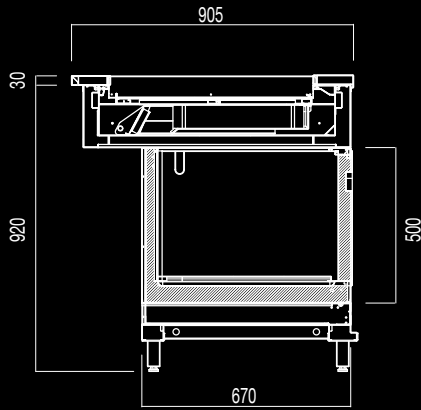
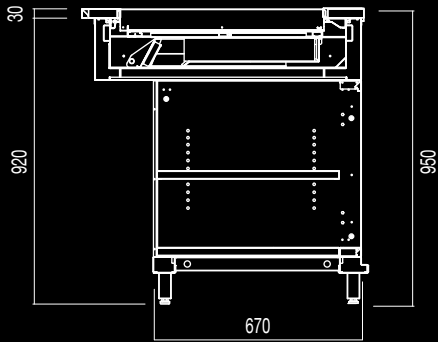

REFRIGERATO VENTILATO
REFRIGERATED VENTILATED

REFRIGERATO DOPPIA
FUNZIONE CALDO FREDDO
REFRIGERATED WITH DOUBLE
SYSTEM HOT/COLD

**MODULO NEUTRO CON TECA A VETRI ALTI
MENSOLA INTERMEDIA OPTIONAL**
NON-REFRIGERATED MODULE WITH HIGH GLASS
STRUCTURE AND OPTIONAL INTERMEDIATE SHELF

MODULO NEUTRO CON TECA IN VETRO BASSA
NON-REFRIGERATED MODULE WITH LOW GLASS STRUCTURE

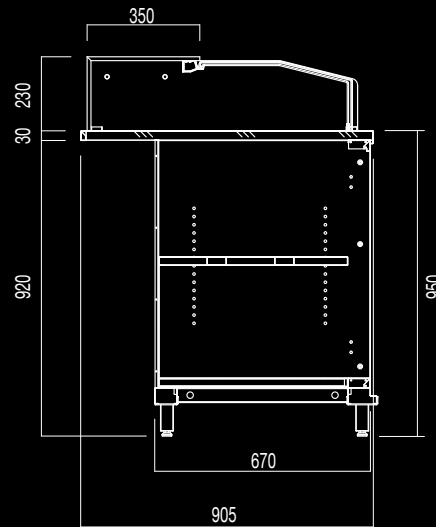
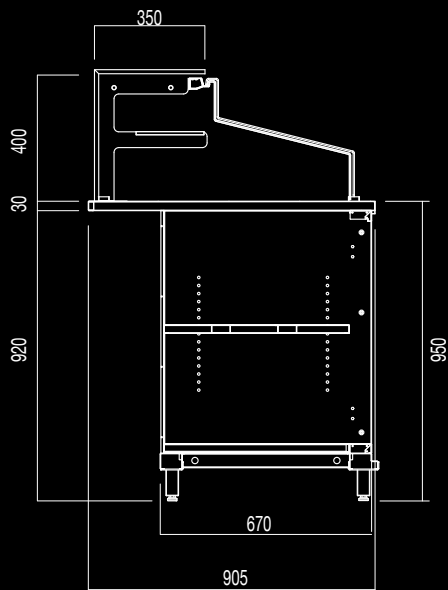

MODULI NEA: 850 / 1250 / 1650 / 2050
NEA DISPLAY CASE MODULES: 850 / 1250 / 1650 / 2050

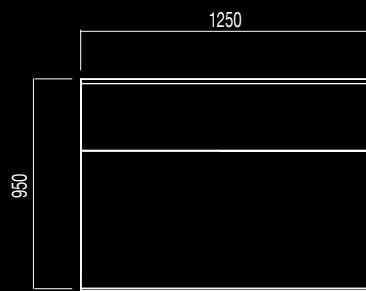
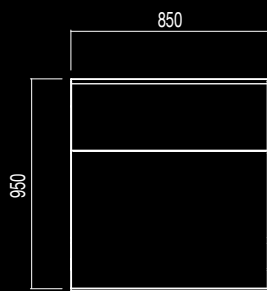

**MODULO NEUTRO
CON E SENZA TECA VETRO**
NON-REFRIGERATED MODULE WITH
AND WITHOUT GLASS STRUCTURE

**MODULO NEUTRO
CON E SENZA TECA VETRO**
NON-REFRIGERATED MODULE WITH
AND WITHOUT GLASS STRUCTURE

**MODULO NEUTRO
CON E SENZA TECA VETRO**
NON-REFRIGERATED MODULE WITH
AND WITHOUT GLASS STRUCTURE

MODULO NEUTRO
NON-REFRIGERATED MODULE

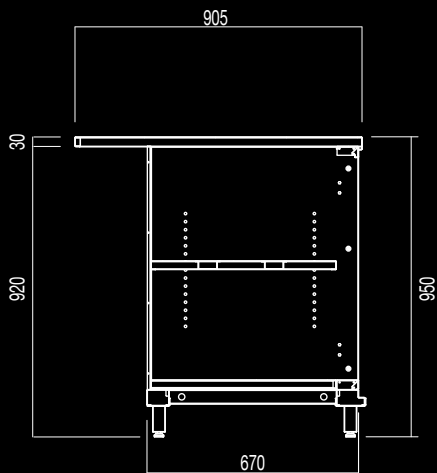

ANGOLO 90° SX/DX
90° RIGHT /LEFT CORNER

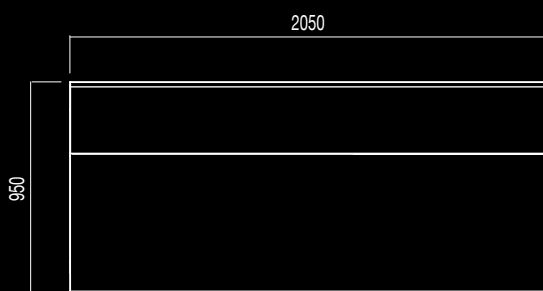

MODULO NEUTRO
CON E SENZA TECA VETRO
NON-REFRIGERATED MODULE WITH
AND WITHOUT GLASS STRUCTURE

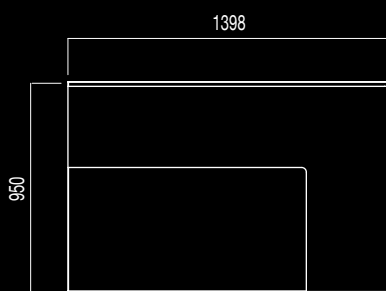

MODULO NEUTRO
CON E SENZA TECA VETRO
NON-REFRIGERATED MODULE WITH
AND WITHOUT GLASS STRUCTURE

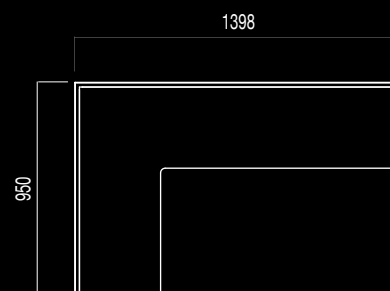

MODULO NEUTRO
CON E SENZA TECA VETRO
NON-REFRIGERATED MODULE WITH
AND WITHOUT GLASS STRUCTURE

BRX srl

Via Luciano Lama, 38/1
61025 Montelabbate (PU) Italy
T +39 0721 499611
F +39 0721 909376
info@brxitalia.com
www.brxitalia.com

Credits

This catalogue
has been made by BRX
in collaboration with

Project coordinator
feligioni.it

Art direction
Giorgio Cristofani
Graphic layout
Daniele Feligioni

Copy and translations
Wahid Jabr

Color separation
Selecolor Firenze
Printed
Grapho5

October 2015

IL CATALOGO È DI PROPRIETÀ BRX SRL. TUTTI I DIRITTI SONO RISERVATI.
È VIETATA OGNI FORMA DI RIPRODUZIONE ANCHE PARZIALE.

*THIS CATALOGUE IS OF EXCLUSIVE PROPRIETÀ OF BRX SRL. ALL RIGHTS
ARE RESERVED. ANY FORM OF TOTAL OR PARTIAL REPRODUCTION OF
CATALOGUE IS STRICTLY FORBIDDEN.*

BRX SRL SI RISERVA DI APPORTARE MODIFICHE AI DATI E I DETTAGLI DEI
PRODOTTI PRESENTI SU QUESTO CATALOGO ANCHE SENZA PREAVVISO.
*BRX SRL MAY AT ANY TIME MODIFY THE SPECIFICATIONS AND DETAILS OF
THE PRODUCTS PRESENT IN THE CATALOGUE.*



HOREQUIP
QUALITY & SERVICE

www.horequip.es

